

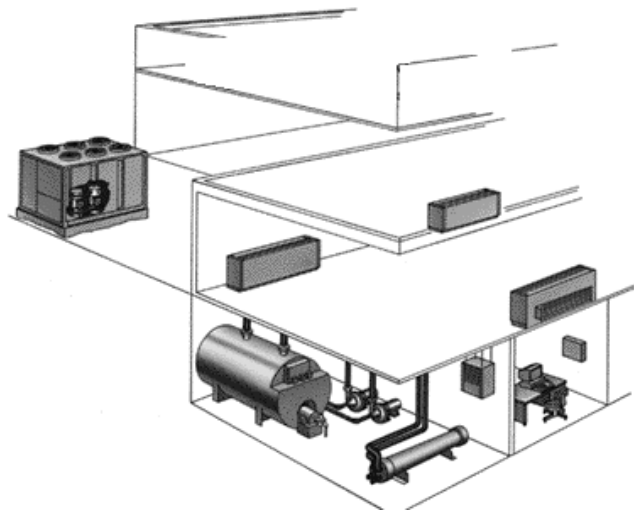

Engineering Bulletin

Active Humidity Control With Unit Ventilator Systems



UV-EB-11-497 (EN)



Preface

Indoor air quality (IAQ) can be influenced by a number of different factors. These include airborne particles or “particulate matter,” odors, internally generated chemicals (volatile organic compounds or VOC’s), and microbial organisms such as mold and mildew.

This engineering bulletin focuses on the use of **active** space relative humidity control to improve comfort and discourage the growth of mold and mildew in buildings with unit ventilator systems. It’s specifically intended for HVAC system designers and Trane field sales engineers.

Contents

Why Manage Relative Humidity?	3
The Classroom Challenge Of Comfort Conditioning	5
How Classrooms “Work”,	5
Latent vs. Sensible Peak Loads	6
ASHRAE Control Cycles,	7
Managing Humidity With Terminal Systems	8
The “Cold Coil” Approach,	8
“Cold Coil” With Post-Conditioning,	9
Outdoor Air Preconditioning,	9
Active Dehumidification Control	11
What Is It?	11
Control Sequences ...	
Heating,	12
Cooling/Heating Transition,	12
Cooling,	13
Dehumidification Cooling Plus Reheat,	13
Dehumidification Transition,	13
Dehumidification Heating,	13
System Application Considerations	14
Economizer Operation,	14
Freeze Protection,	14
Humidistat Or Humidity Sensor?	15
Unit Operating Modes,	15
Stand Alone Or Tracer Summit®?	16
Unit Ventilator Selection,	16
Cooling Coil,	17
Reheat Coil,	21
System Component Coordination,	22
Other Considerations For Good IAQ,	26

Why Manage Relative Humidity?

Uncontrolled humidity levels in a building can adversely impact occupant comfort and health. ASHRAE Standard 55–1992, *Thermal Environmental Conditions for Human Occupancy*, specifies that the optimum comfort range for indoor relative humidity (RH) is between 30% and 60%; see Figure 1. Besides the effect on comfort and health, high indoor humidity levels can damage a building’s furnishings and mechanical systems—even its structure—leaving the owner with considerable maintenance or renovation expense.

ASHRAE Standard 62–89, *Ventilation for Acceptable Indoor Air Quality*, supports the 30%–60% RH range, and the proposed “89R” version currently under revision goes a step further. It not only specifies space relative humidity limits for occupied periods, but for **unoccupied** times as well to reduce the potential for growth of mold, mildew and fungi around the clock.

Keep in mind that mold and fungi need four things to live and reproduce:

- **Organic material for food.** Food for microorganisms is always present in any building. Dirt is the most common source, though cellulose-based materials (e.g. certain ceiling tiles and wall coverings) are another excellent nutrient. Filtration and housekeeping can reduce the availability of food, but it’s impossible to completely eliminate all dirt inside a building and its mechanical systems.
- **Consistent temperatures between 40°F and 100°F.** Indoor environments are typically controlled for human comfort, which also happens to coincide with the temperatures at which microorganisms thrive.
- **A source of spores.** Spores are always present in both indoor and outdoor air, and are released when mold and fungi reproduce. They eventually settle on surfaces and grow (if there’s food and moisture). Again, filtration and housekeeping can reduce the spore population, but it’s impossible to rid them entirely from the building.

Figure 1
ASHRAE-Recommended Relative Humidity Range

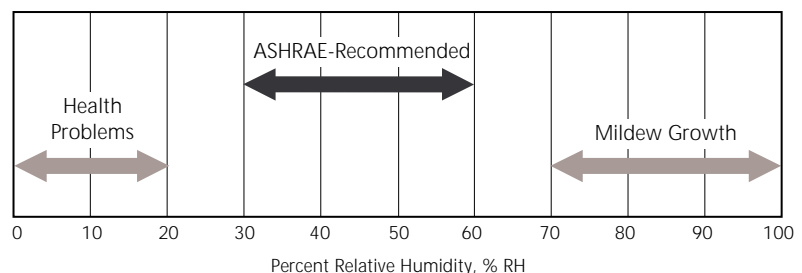



Why Manage Relative Humidity?

- **Moisture in the form of free water.** While proper filtration and careful selection of building materials can reduce the food supply, moisture control can be the most effective means of curbing microbial growth.

The condensate that collects on the cooling coils during the cooling and dehumidification process must be managed. Sloped drain pans that fully remove condensate and equipment designs that limit moisture carryover can greatly reduce wet surfaces and standing water inside HVAC equipment. Obviously, rainwater leaks are unacceptable and must be repaired immediately.

In addition to liquid water, relative humidities over 60% within the building can cause moisture to migrate (by vapor pressure action) into porous materials; free water in porous materials also supports microbial growth. Moisture in the form of water vapor can enter the building along many paths. Typically, outdoor air brought in for ventilation is the principal source of water vapor. That's because proper use of vapor barriers and building pressurization can control air and moisture infiltration through the building envelope.

Internal latent loads (people, infiltration via doors and processes) dictate the psychrometric characteristics of the supply air needed to satisfy the target condition for the space. Unfortunately, most past HVAC designs concentrated only on controlling sensible temperature. Control of **latent energy** (humidity) was coincidental—a by-product of the sensible cooling process. Though average outdoor wet bulb conditions were taken into account when a system's design conditions were determined, the ability of the system to properly dehumidify (especially during part-load operation) was often overlooked.

Since a building spends most of its life at "off-peak" conditions, careful attention to how the system operates at part load is crucial to proper humidity management and microbial growth control. It's also important to consider how the occupied space will be used when selecting the system type and control schemes.

The Classroom Challenge Of Comfort Conditioning

For years, unit ventilators—with their zoning flexibility, easy maintenance and relatively low first cost—have been the favorite HVAC system of schools. Early applications provided only heating and ventilation since operable classroom windows typically handled cooling and ventilation needs. Mechanical cooling in schools has become common during the last decade, expanding the unit ventilator’s role to include cooling duty.

How Classrooms “Work”

Providing proper comfort-conditioning for classrooms can be challenging. Typically, the occupant density in classrooms is much higher than that found in office or retail spaces, greatly increasing both the amount of ventilation air required and internally-generated sensible and latent loads. Students also move through the building in groups; that means the HVAC system must respond to widely varying thermal loads within the zones. This situation is further aggravated by the fact that classrooms are usually located around the perimeter of the building, making them sensitive to varying outdoor temperatures and solar loads.

Along with heating and cooling, unit ventilators are now expected to condition and dehumidify outdoor ventilation air. To save energy, economizer cycles that use up to 100% outdoor air (OA) are commonly used to delay mechanical cooling. Though economizing may satisfy the room’s sensible temperature requirements, it can result in unacceptably high indoor relative humidity (RH) levels whenever the outdoor air dew point exceeds the supply level needed to offset internal moisture gains. This condition often occurs in the morning during the traditionally cool and wet months of spring and fall. Even if the unit switches to mechanical cooling at some point during the day, the sensible load may not be high enough—or the unit may not operate long enough—to adequately reduce the humidity level below 60% RH.

Latent vs. Sensible Peak Loads

Cooling coils can effectively remove water vapor from the air. However, as discussed earlier, their ability to dehumidify is usually only considered at design conditions or (unfortunately) many times not at all. The unit's cooling coil is controlled solely from the room's dry bulb (sensible) temperature, which does not assure regulation of the space relative humidity. Why? Peak sensible and latent loads seldom occur at the same time; see Figure 2. While a high student density and doorway infiltration give classrooms a large, fairly constant internal latent load, the sensible load varies greatly based on outdoor conditions.

The basic dilemma stems from trying to control two variables—**temperature** and **relative humidity**—with one device: the cooling coil controlled by space temperature.

A unit ventilator is a constant-volume, variable-temperature device that uses a constant fan speed and modulates water flow through a chilled water coil to regulate the temperature in the space. With respect to dehumidification, the problem is that as the water flow through the coil is modulated, the surface temperature of the coil increases and reduces the coil's ability to remove moisture. The moisture in the outdoor ventilation air, along with the internally generated moisture from respiration, cooking, carpet cleaning, etc., can result in indoor humidity levels well above the 60% RH limit recommended to control microbial growth.

Many designers attack this problem by oversizing the unit ventilators, usually in terms of airflow. This does **not** solve the problem; in fact, it can make the situation worse. A higher airflow raises the cooling coil's sensible heat ratio, sometimes to such an extent that it may not adequately dehumidify the space—even on a design day. It's important to understand that this is not just a unit-, coil- or fan-sizing challenge. Rather, it's an issue of properly regulating the cooling coil in a manner that provides sufficient latent capacity at all

Figure 2
Latent And Sensible Load Peaks Seldom Coincide

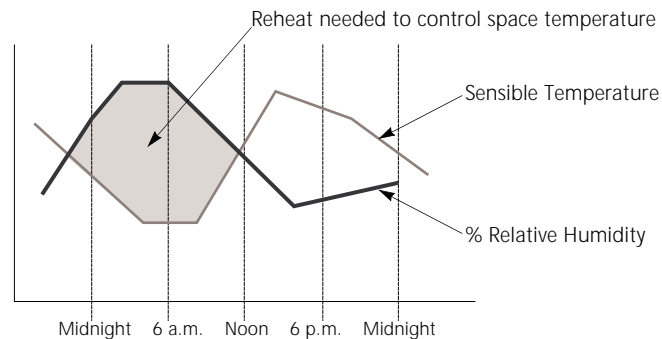

Latent vs. Sensible Peak Loads

operating conditions. **Proper dehumidification with terminal units is a matter of control.**

ASHRAE Control Cycles

There are various ways to control unit ventilators. Traditionally, unit ventilators applied in classrooms have been controlled according to ASHRAE Cycle I, II or III. Each of these ASHRAE cycles basically describes how to regulate the outdoor air damper in relation to the heating control valve. Mechanical cooling and dehumidification operation are not addressed.

For more information on ASHRAE unit ventilator control cycles, see Trane's unit ventilator product catalog, UV-DS-1.

Managing Humidity With Terminal Systems

Controlling the mold and mildew growth that can result from excessive indoor humidities means that humidity control must be an integral element of unit ventilator system design and control. In systems of this type, a “cold coil” provides sensible cooling and dehumidification. Adding conditioners upstream and/or downstream of the coil can enhance unit performance.

The following discussion briefly describes how pre- and post-conditioning options applied to unit ventilators can affect management of relative humidity in the space.

The “Cold Coil” Approach

The traditional unit ventilator technique for controlling humidity relies on a cooling coil regulated to maintain the space sensible temperature. It's considered a **passive** approach to humidity management since there's no humidity data in the control loop. In operation, a mixture of return air and outdoor air passes over a cold, finned-tube coil. As the air temperature falls below its dew point, moisture in the air stream condenses on the coil's cold surface. The psychrometric chart in Figure 3 depicts the effect of this process. A unit's ability to dehumidify the space is determined by its leaving air temperature (LAT). Notice that the sensible heat ratio (SHR) becomes steeper at part load. Though the thermostat maintains the room's sensible temperature target, the coil's leaving-air temperature rises; that prompts an increase in the room dew point temperature (Room' Condition).

The increased outdoor air requirements of ASHRAE Standard 62–1989 can prescribe 35%–50% OA in classrooms. Given the amount of water vapor that can be introduced with the outdoor air, along with the potential for high latent loads due to human respiration, the unit ventilator's ability to dehumidify the space is critical.

Figure 3
“Cold Coil” Dehumidification (Sensible Control Only)

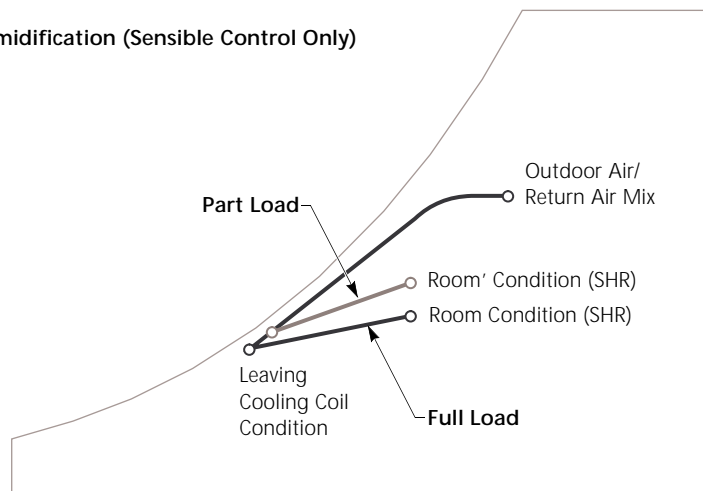

Managing Humidity With Terminal Systems

“Cold Coil” With Post-Conditioning

This variation of the basic “cold coil” concept conditions the air leaving the cooling coil. See Figure 4. Recall that a unit’s ability to dehumidify the space is closely related to its leaving air temperature (LAT). However, during periods of low sensible loads and high humidity within the space, the LAT that results from sensible-only control can’t satisfy space dehumidification needs. On the other hand, the LAT provided by latent control to meet dehumidification needs will overcool the space. In such situations, post-conditioning in the form of reheat can be used to raise the supply air temperature to a level that can maintain the target space temperature. Trane’s **active dehumidification control** is an example of a post-conditioning control strategy.

Figure 4
“Cold Coil” Dehumidification With Post-Conditioning Reheat

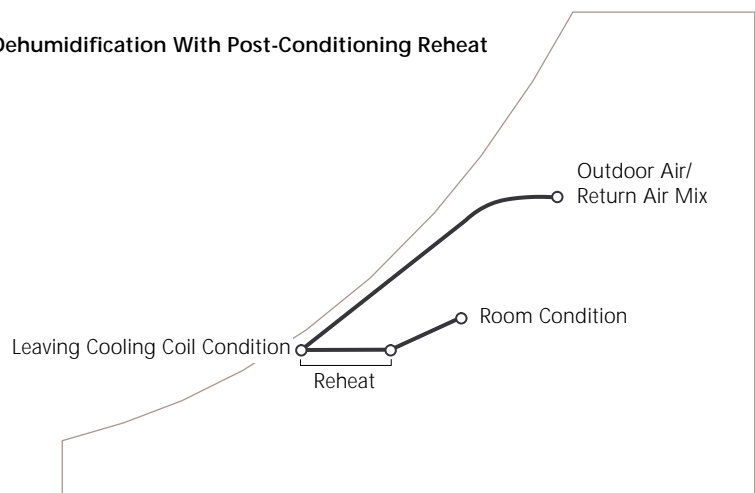

Outdoor Air Preconditioning

Conditioning the large amounts of outdoor air required for proper classroom ventilation can significantly increase building cooling and heating loads—it also raises the system’s first cost and operating cost. One way to reduce the impact of the outdoor air load on the unit ventilator is to use energy recovered from the exhaust air stream to precondition the outdoor air as it’s brought into the building.

To maintain proper pressurization inside the building relative to outside, fresh air and exhaust air must be balanced. Air exhausted from the building has already been cooled, heated and/or dehumidified. Rotary air-to-air heat exchangers, also known as heat or energy wheels, offer a means of recovering the “conditioning” energy contained in the exhaust air stream. These devices consist of a revolving cylinder filled with a desiccant-coated medium suitable for sensible and latent heat transfer. (See Figure 5 on page 10.) The adjacent outdoor and exhaust air streams pass through the wheel in a counterflow

Managing Humidity With Terminal Systems

Figure 5
Energy-Recovery Wheel

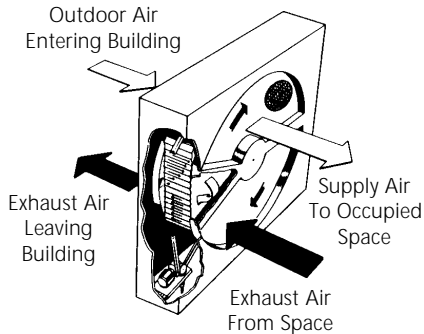

arrangement that transfers energy from one air stream to the other. During the cooling season, the drier, cooler exhaust air dehumidifies and precools the incoming outdoor air. Conversely, heat and humidity from the exhaust air passes to the entering outdoor air stream during the heating season. Figure 6 psychrometrically depicts the impact of a preconditioning energy wheel on a unit ventilator.

This approach can't directly control humidity in the space. But it **can** significantly reduce the capacity (and operating cost) of the cooling equipment required to condition the outdoor air. Capable of recovering 65%–75% of the energy in the exhaust air stream, heat wheels used in conjunction with unit ventilators can be an attractive alternative when upgrading existing classrooms to meet ASHRAE's ventilation requirements; they reduce, perhaps even eliminate, the extra capacity needed at the chiller plant.

Trane's **ERSA energy-recovery unit ventilator** is one example of a "cold-coil" unit with outdoor-air preconditioning.

Note: Both pre- and post-conditioning can be applied to the same unit.

Figure 6
"Cold Coil" With Outdoor Air Preconditioning

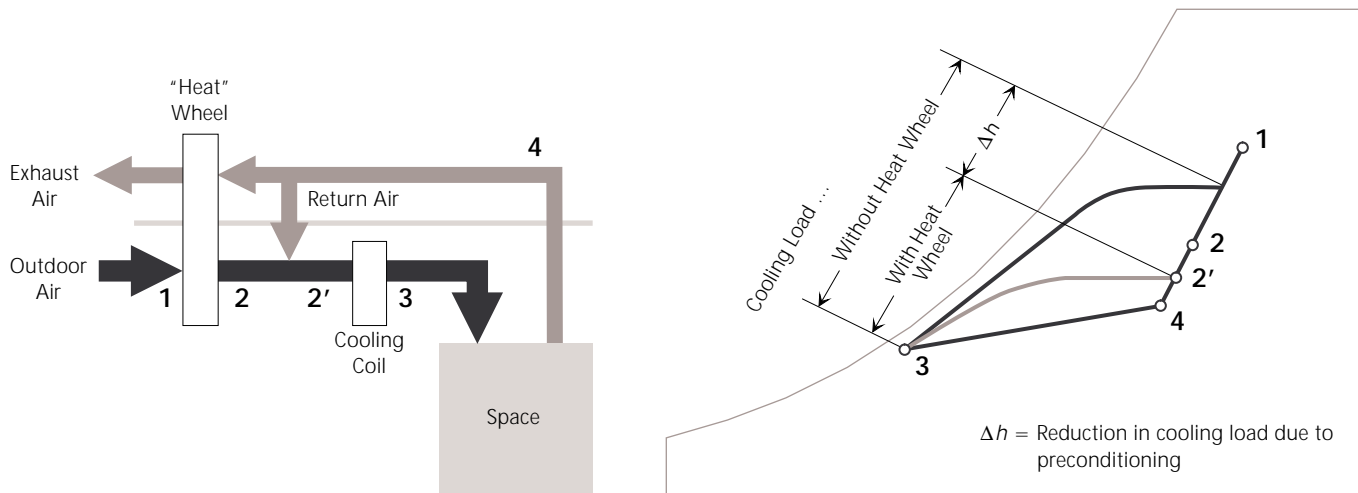

Active Dehumidification Control

What Is It?

Active dehumidification control, which includes cooling-coil-with-post-conditioning (reheat) control, is available with the Terminal Unit Controller (TUC) on Trane classroom unit ventilators. The algorithms associated with this control option were specifically designed to govern both space temperature and relative humidity. They minimize the amount of reheat needed to maintain the space relative humidity below a preset limit. **Reheat is used only when required**, and is operated in the most energy-efficient manner for the system. Reheat energy can be recovered from the chilled water system (preferred) or provided as “new” energy; see “Reheat Energy Sources” on page 24.

Basic components of the system (shown in Figure 7) include:

- A unit ventilator with a main coil and an auxiliary coil downstream.
- A direct-digital-control (DDC) Terminal Unit Controller or “TUC.”
- Two sensors, one for temperature and one for relative humidity, located either in the zone or in the return air stream.

If scheduling or after-hours operation is required, the addition of a building automation system (BAS) such as a Tracer Summit® is recommended to coordinate the chillers, pumps, boiler and unit ventilators, and to assure proper operation of the exhaust fans.

Control Sequences

Trane’s **active dehumidification control** strategy automatically determines the proper control sequence and continuously resets the unit ventilator’s leaving air temperature, as needed, to manage both the temperature and

Figure 7
Basic Components Of Trane’s Active Dehumidification Control For Unit Ventilators

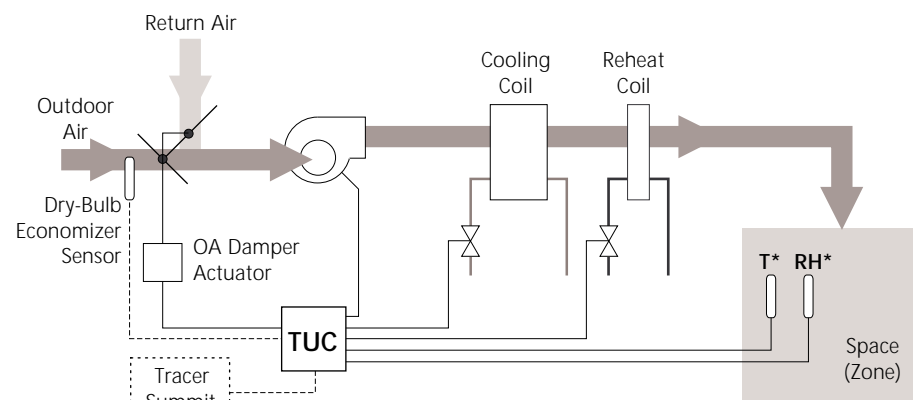

*The temperature (T) and relative humidity (RH) sensors can be installed in the space **or** in the return air stream.

Active Dehumidification Control

relative humidity sensed in the space. This approach overcomes the deficiencies of other means of control based on temperature alone.

To help explain how **active dehumidification control** works, the psychrometric chart in Figure 8 depicts its operating modes; the relationship between these control sequences is defined by the cooling and heating set points and the relative humidity limit.

Figure 8
Active Dehumidification Control Sequences

Control Sequences/Operating Modes ...

- 1 Heating
- 2 Cooling/Heating Transition
- 3 Cooling
- 4 Dehumidification Cooling Plus Reheat
- 5 Dehumidification Transition
- 6 Dehumidification Heating

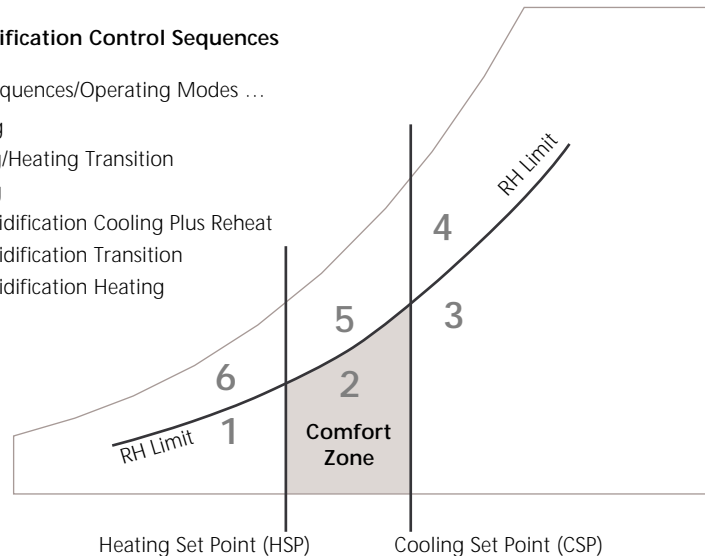

Region 1 ...

Heating

Normal heating control activates whenever zone conditions fall within the area labeled **Region 1** in Figure 8—that is, when there’s a call for heating and the relative humidity sensed in the zone is below the RH limit. During this operating mode, a proportional-integral (PI) algorithm controls only the zone’s sensible temperature to satisfy the heating set point (HSP). The OA damper is set at its minimum position, and reheat is not used.

Region 2 ...

Cooling/Heating Transition

TUC initiates this control sequence whenever space conditions fall between the heating and cooling set points and the space relative humidity (RH) is below the RH limit—i.e. **Region 2**. If the unit enters this mode from normal heating, it will continue to control to the heating set point (HSP). Similarly, if the unit enters this mode from normal cooling, the cooling set point (CSP) remains in effect. In both cases, the OA damper is set at its minimum position, the economizer cycle is available if conditions are suitable, and reheat is disabled.

Active Dehumidification Control

Region 3 ...

Cooling

Region 3 of Figure 8 represents the conditions that trigger normal cooling; that is, the zone thermostat signals a call for cooling and the relative humidity detected is below the RH limit. During this operating mode, a PI algorithm controls only the zone's sensible temperature to satisfy the cooling set point. Economizer operation is enabled and will operate if conditions are suitable. Reheat is disabled.

Region 4 ...

Dehumidification Cooling Plus Reheat

TUC initiates the **active dehumidification control** sequence whenever the zone temperature exceeds the cooling set point and the zone relative humidity exceeds the preset RH limit. **Region 4** in Figure 8 depicts these conditions psychrometrically.

In this mode, the cooling water valve opens fully to dehumidify the mixture of outdoor and return air. The reheat coil then reheats the air leaving the cooling coil as necessary to maintain the zone's cooling set point. Active dehumidification begins when the space relative humidity exceeds the preset RH limit and continues until the humidity falls below the preset RH "stop" point (typically 10% below the RH limit). Throughout this sequence, the OA damper is set at its minimum position, **the economizer cycle is disabled**, and the unit fan operates continuously at a preset speed.

Region 5 ...

Dehumidification Transition

This operating mode occurs if the humidity detected in the space exceeds the RH limit and the zone thermostat is calling for heat; **Region 5** represents these conditions. When they exist, TUC will heat the zone to the occupied cooling set point in an effort to reduce the relative humidity below the RH limit. If this doesn't happen by the time the zone temperature reaches the cooling set point, TUC switches to Dehumidification Cooling Plus Reheat (Region 4). The cooling water valve is positioned wide open and reheat will be used to maintain the CSP.

Region 6 ...

Dehumidification Heating

TUC activates this sequence if the zone temperature is below the heating set point and space humidity exceeds the RH limit, as represented by **Region 6**. The unit will heat the space, attempting to reduce the humidity below the RH limit. If that doesn't happen before the space temperature reaches the occupied cooling set point, TUC switches to Dehumidification Cooling Plus Reheat (Region 4).



System Application Considerations

Economizer Operation

In the economizer mode, unit cooling and heating capability is disabled and the economizer damper modulates between the minimum ventilation setting and 100% open in response to the room thermostat. Economizing during periods when outdoor air is cool and dry can substantially reduce the amount of mechanical cooling required for a classroom. **Adjust the economizer set point to match the design leaving air temperature** calculated in the unit selection procedure (i.e. described on page 18).

Freeze Protection

Building location may dictate some form of freeze protection for the cooling coil. In unit ventilator systems, freeze protection usually entails glycol, heating-cooling changeover, and/or water circulation. (The blow-thru arrangement of Trane unit ventilators inherently offers some protection from freezing—outdoor air mixes with warm return air before passing through the cooling coil.)

Glycol

Dedicated water loops are provided for the cooling and heating coils in a straight, four-pipe unit ventilator configuration that includes reheat coils. Since the cooling coil is first in the mixed air stream and is usually inactive during heating operation, a mixture of ethylene or propylene glycol and water is required to prevent freeze-up.

***Note:** Glycol affects chiller and coil heat transfer performance as well as the chilled water system's pressure drop. Be sure to consider this during the selection process.*

Heating-Cooling Changeover

This variation of the straight, four-pipe configuration reverses the heating and cooling water circuits during the heating mode. In effect, the heating coil is now first in the air stream and the downstream, now-inactive coil is protected from freezing. Unless the possibility of freeze-up exists during extended "off" cycles, glycol typically isn't required.

Water Circulation

Moving water is less likely to freeze than water that's standing. So another option for temperate climates that don't experience extremely low outdoor temperatures is to open the chilled water valves on the unit ventilators and operate the chilled water pumps whenever the outdoor temperature approaches freezing, i.e. 35°F.

System Application Considerations

Humidistat Or Humidity Sensor?

It's important to note the difference between these two devices. A **humidistat** simply provides a binary output signal based on the level of relative humidity it detects in the space. Basically, it indicates only whether the humidity is above or below the preset limit. A **humidity sensor**, on the other hand, issues a signal that's *proportional* to the humidity level in the space. This analog signal can be used by a building automation system for documentation, trending and troubleshooting, as well as for space control.

Trane's **active dehumidification control** option uses a humidity sensor located either on the wall in the space or in the return air section of the unit.

Unit Operating Modes

Occupied

This mode is used whenever the space is normally occupied. The system maintains the specified heating and cooling set points, and can control the indoor relative humidity to a preset limit if configured to do so. Unit operation is described on pages 11–13.

Unoccupied

During after-hours operation, the unit ventilator maintains the unoccupied cooling and heating set points. Dehumidification control is disabled and the OA damper is closed.

Standby

This mode is similar to unoccupied operation, except that the unit can maintain a unique cooling set point, heating set point and OA damper setting. Continuous operation of the unit-ventilator fan assures air circulation within the space to avoid humidity stratification in cooler areas (e.g. near windows and along floors).

This mode can be used after hours, or for humidity and/or ventilation control during summer shutdown.



System Application Considerations

Stand Alone Or Tracer Summit®?

A Tracer Summit building management system is recommended to realize the full benefits of active dehumidification control. For applications that require stand-alone TUC operation, binary inputs from time clocks or some other building automation system can be used.

Tracer Summit

All controller set points can be viewed and edited from a central location if a Tracer Summit building management system is applied with TUC-equipped unit ventilators. The Tracer Summit system can schedule unit operating modes, and coordinate the start-up and operation of other components in the system such as the chiller(s), boiler and pumps. System coordination becomes especially important when after-hours dehumidification control is desired (i.e. Standby mode, or during a “dry-down” cycle as described on page 23).

Tracer Summit can also be an effective tool for documenting system operation to assure that ventilation and humidity levels are controlled as intended.

Stand-Alone Operation

In a stand-alone arrangement, *EveryWare™* service software must be used at each unit to view the controller configuration and make changes to the setup. Changeover between operating modes—occupied, unoccupied and standby—can be accomplished with isolated 24 VAC binary inputs to the unit controller.

Unit Ventilator Selection

Proper sizing of the unit ventilator is crucial to its ability to control relative humidity in classrooms. Contrary to what one might first think, oversizing unit ventilators without active humidity control can actually **reduce** the unit’s ability to dehumidify. In particular, oversizing fan airflow results in higher coil leaving air temperatures; these LAT’s often exceed the space dew point target, and can lead to humidity problems in the space. The specific unit ventilator selection procedure is well-documented in Trane product catalog UV-DS-1. The following section supplements that information by looking at unit selection and sizing from a load analysis (psychrometric) perspective. Because we’re concentrating on proper dehumidification performance, this discussion is limited to selection of the cooling and reheat coils; the importance of unit airflow is also addressed.

The following example sizes a unit ventilator for a standard classroom located in Columbus, Ohio. The classroom is of typical size and average glass area with energy-conserving lighting. It’s designed for a teacher and 30 students, and the designer intends to ventilate the space in compliance with ASHRAE Standard 62–1989 by providing 15 cfm per person.

System Application Considerations

Here are the **specific design criteria** for our example classroom:

- 1,024 sq ft (32 ft x 32 ft)
- Moderate daylighting
- Energy-efficient lighting (T8 with electronic ballast)
- 30 students, 1 teacher

Cooling Coil

- 1 Determine the internal sensible load.** “Sensible loads” are those detected by the space temperature sensor. They do not include latent loads generated inside the building or brought in with outdoor ventilation air.

The T8 lights in our example classroom add 1.5 watts/sq ft or **5,240 Btu** to that space (1.5 watts × 1024 sq ft × 3.413 Btu/watt). Sensible heat gain from the occupants comprises that from the 30 students—which is calculated at 75% of the adult rate, or 175 Btu/student—plus that from the adult teacher (230 Btu), for a total of **5,480 Btu**. The remaining sensible heat gain is from the walls, windows, roof and infiltration through cracks, and is estimated at **8,295 Btu** for this example. This results in a total space sensible load of **19,015 Btu** (about 1.5 tons).

- 2 Determine the target space conditions.** As discussed earlier, humidities above 60% RH can result in moisture levels high enough to support microbial growth in building materials. For this reason, a design target of 60% RH or slightly less is recommended. In this example, we’ll add a 5% RH safety factor (i.e. 3 percentage points) and use a classroom target of **75°F DB, 57% RH**. From a psychrometric chart, we find that the resulting dew point at this condition is 59°F. Said another way, the cooling coil’s leaving air temperature (LAT) must be 59°F or less to maintain the space relative humidity at or below 57% RH.

- 3 Determine the internal latent load.** Internal latent loads in a classroom result from the respiration of the occupants, infiltration and processes (e.g. cooking) that occur there. The latent load of outdoor air need not be considered here; it will be accounted for later when we determine the mixed air condition entering the cooling coil.

An analysis of this building determined that the latent load attributable to infiltration is **1,625 Btu**. Assume that our example classroom isn’t subject to any special processes with associated latent loads. That still leaves the “people” latent load to be considered. According to ASHRAE (*1985 Fundamentals Handbook*), the latent load for students in a classroom is



System Application Considerations

75% of the adult rate (190 Btu) or 145 Btu. That means the latent load contributed by the people in our example classroom is **4,540 Btu**—i.e. (30 students × 145 Btu) + (1 teacher × 190 Btu).

When we add together both latent loads, infiltration and people, we find that the classroom's total internal load is **6,165 Btu**—i.e. 1625 + 4540.

Note: *Two forms of infiltration must be considered. One is infiltration through leaks in the building structure such as cracks and leakage through/around closed windows and doors. Loads from this type of infiltration can be easily estimated and are considered in our example. Also, "crack" infiltration can be greatly reduced by keeping the building properly pressurized at all times.*

The other type of infiltration results from the intrusion of outdoor air through open doors, and is especially prevalent in schools. Local, short-term pressure differences and turbulence occur as doors are opened and closed; that can pull outdoor air into the building even if it's under positive pressure. The effect of open doors on building loads is highly dependent on the layout of the school. It's important to consider the effects of this type of infiltration, but our example does not take it into account since it's highly variable.

- 4 Determine the space sensible heat ratio (SSHR).** The SSHR describes the sensible load of the space relative to the total load. To calculate it, we'll use the space sensible load calculated in Step 1 and the latent load determined in Step 3.

$$\begin{aligned} \text{SSHR} &= \text{space sensible load} / \text{total load (sensible and latent)} \\ &= 19,015 / (19,015 + 6,165) \\ &= \mathbf{0.76} \end{aligned}$$

- 5 Determine the required leaving air temperature (LAT).** Knowing the SSHR, we can use a psychrometric chart to determine the required leaving air temperature from the cooling coil. The leaving air temperature necessary to meet space loads and maintain the target conditions desired for the room can be found at the point where the SSHR line intersects with the 95% RH line on the "psych" chart. (The 95% RH curve is a realistic operating condition leaving most coils.) As shown in Figure 9, the leaving air temperature from the cooling coil would have to be 57°F to satisfy the target space condition of 75°F DB, 57% RH.

Note: *The air's dry-bulb temperature must be an additional 2°F cooler than our target dew point to handle the internally generated latent load from occupants and "crack" infiltration.*

System Application Considerations

- 6 Determine the unit airflow (V_s).** The next step is to calculate the unit airflow necessary to meet the room target.

$$\begin{aligned} V_s &= \text{Sensible Load} / (1.085 \times \Delta T) \\ &= 19,015 / [1.085 \times (75^\circ\text{F} - 57^\circ\text{F})] \\ &= \mathbf{974 \text{ cfm}} \end{aligned}$$

The appropriate selection for this example would be a Model HUVA-100, a unit with a nominal airflow of 1,000 cfm.

- 7 Calculate the design ventilation rate (DVR).** The amount of outdoor air needed to properly ventilate the classroom is determined with this equation:

$$\begin{aligned} \text{DVR} &= \text{ASHRAE rate} \times \text{number of people} \\ &= 15 \text{ cfm/person} \times 31 \text{ people (i.e. 30 students, 1 teacher)} \\ &= \mathbf{465 \text{ cfm}} \end{aligned}$$

- 8 Determine the entering cooling coil conditions.** Air entering the cooling coil will be a mixture of outdoor air and return air from the space. The temperature of that mixture can be determined with a psychrometric chart or a computer program. To identify the correct outdoor air condition at design, **compare the enthalpy** for the ASHRAE Design Dry Bulb and Mean Coincident Wet Bulb conditions (traditional approach), **and** the

Figure 9
Determine Leaving Air Temperature (LAT)

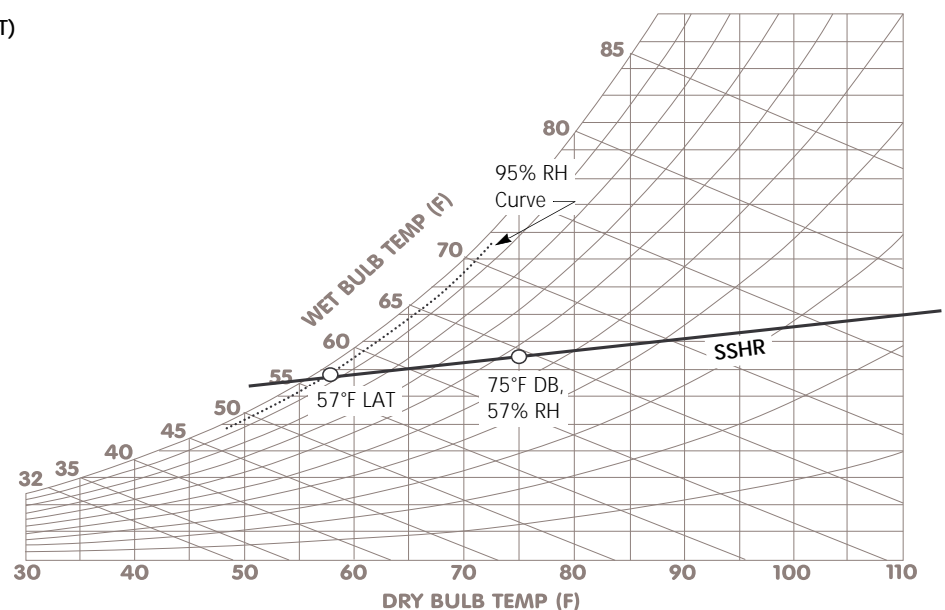

System Application Considerations

recently released ASHRAE Design Dew Point Temperature and Mean Coincident Dry Bulb Temperature. Be sure to use the condition with the **highest** enthalpy. For Columbus, OH, the 1% ASHRAE conditions are as follows:

- a) Design Dry Bulb (DB) and Mean Coincident Wet Bulb (WB) Temperatures: **91°F DB** and **73°F WB**.
- b) Design Dew Point (DP) and Mean Coincident Dry Bulb (DB) Temperatures: **76°F DP** and **83°F DB**.

As shown in Figure 10, plotting these two conditions on a psychrometric chart determines that the **76°F DP, 83°F DB** condition has the highest enthalpy; so it's the outdoor air condition that should be used for design. Combining 48% outdoor air (465 cfm/974 cfm) at this condition with our classroom's target condition of 75°F DB, 57% RH results in an entering-coil, mixed-air condition of 79°F DB, 71°F WB. See Figure 11.

For this example, cooling coil performance should be scheduled as 974 cfm at 57°F.

Note: *It's important to understand that **the cooling coil's leaving air temperature is key to its ability to properly dehumidify.** There may be situations where local codes specify a required airflow for space circulation*

Figure 10
Select OA Condition With Highest Enthalpy

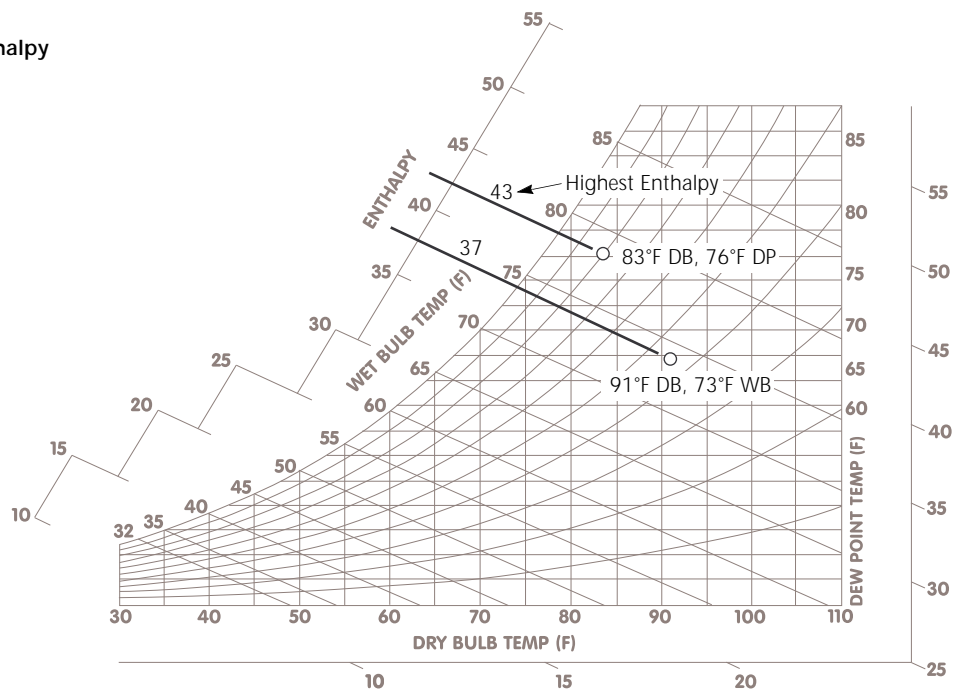

System Application Considerations

Figure 11
Determine Cooling Coil's Entering Condition (Mixed Air)

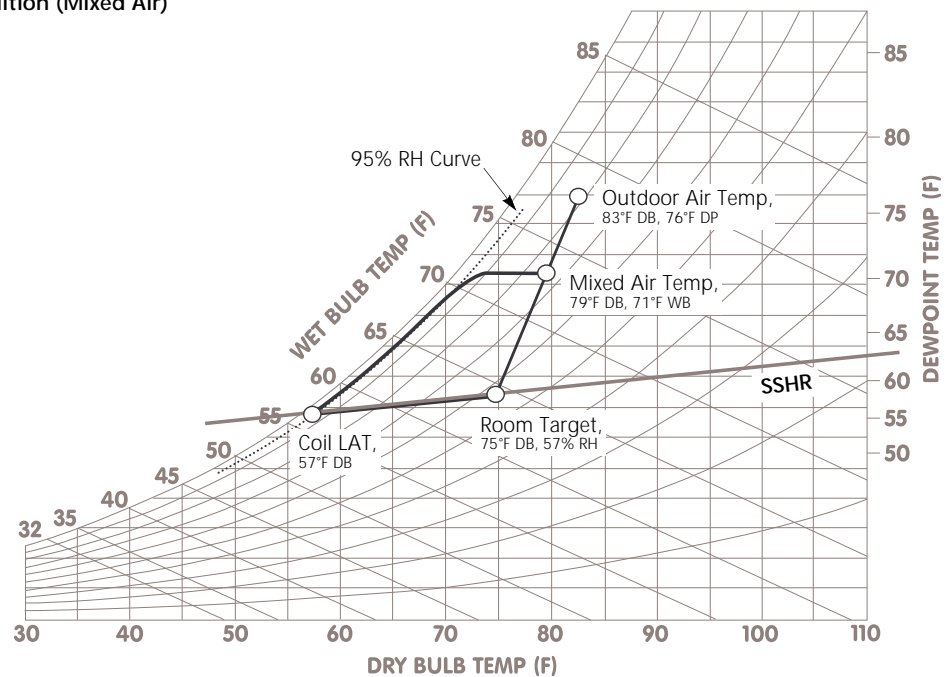

that's higher than the value calculated with the preceding method. If that happens, **the calculated leaving air temperature must be used for coil selection purposes to assure proper dehumidification capacity.** If the unit airflow is increased to meet local codes, the unit will operate in the dehumidification-plus-reheat mode more often than a unit selected as shown in this example.

Using chilled water reset can also compromise the cooling coil's ability to control space humidity. The required leaving air temperature (and, therefore, water temperature) must be maintained to implement this strategy successfully and still provide proper dehumidification.

Reheat Coil

The reheat coil can be selected once the cooling coil conditions are known. Recall that our objective is to control two variables: temperature and humidity. There will be times (e.g. a rainy, spring morning) when a low sensible load/temperature coincides with an unacceptably high relative humidity. When this occurs, the unit controller begins dehumidifying by driving the chilled water valve open. In doing so, the cooling coil's leaving air temperature falls below



System Application Considerations

the room target dew point temperature and begins dehumidifying the passing supply air stream. Reheat is needed to avoid overcooling the space by warming the leaving air.

- 1 Determine the minimum leaving cooling coil temperature.** During our example cooling coil selection, we determined that a 57°F leaving air temperature is needed to satisfy our target space temperature and humidity. However, that analysis was made at the peak design condition. The space sensible heat ratio is usually lower at off-peak or part-load conditions. TUC's dehumidification-plus-reheat control sequence will drive the chilled water valve wide open, even on part-load days, resulting in a leaving air temperature lower than our 57°F design. This minimum temperature must be taken into account when sizing the reheat coil.

After sizing the unit and cooling coil, determine the minimum leaving air temperature (LAT); using the unit selection program simplifies this task. To do so, enter the lowest off-peak entering coil condition with the water flow and temperature fixed at design airflow (cfm). The selection program will calculate the resulting LAT, i.e. typically 2°F to 4°F below the design LAT. For our example, we'll assume the cooling coil's minimum, off-peak leaving-air temperature is 55°F.

- 2 Determine the reheat coil temperature rise.** The reheat coil's design temperature rise is the difference between the target space sensible temperature and the cooling coil's minimum leaving air temperature (LAT).

$$\begin{aligned} \text{Reheat } \Delta T &= \text{Target Space Temperature} - \text{Minimum Cooling Coil LAT} \\ &= 75^\circ\text{F} - 55^\circ\text{F} \\ &= 20^\circ\text{F} \end{aligned}$$

- 3 Select the reheat coil.** We now know the conditions needed to select the reheat coil. At this point, some thought must be given to the reheat energy source. The water temperatures will be different if a traditional hot water boiler is used rather than heat recovered from the water chilling system. See "Reheat Energy Sources" on page 24 for a discussion of the alternatives.

System Component Coordination

Chilled Water And Heating Capability

Simultaneous cooling and reheating are required whenever active dehumidification control is available—i.e. during the occupied and standby modes. That means the chillers, pumps, boilers and other auxiliary equipment required to support these functions must be capable of operating on demand. When active dehumidification control is disabled, as during the unoccupied mode, either the system's chilled water components **or** its heating components must be available to control space temperature within the unoccupied heating and cooling set points.

System Application Considerations

Note: *Sizing the hot water coil appropriately allows the boiler loop temperature to be reset during the cooling season. Rather than providing 180°F water (typical of winter operation), the boiler could provide 120°F water to satisfy reheating needs.*

“Dry-Down” Period

When the selection procedure was described, open doors were identified as a major source of uncontrolled moisture infiltration into the building. Doors remain open for a lengthy time as students leave at the end of the school day. This allows large quantities of potentially moist air to enter the building. The space sensible load drops dramatically once the students are gone. Since it's the sensible load that typically drives unit ventilator operation, little or no passive dehumidification occurs.

To combat this, allow unit ventilators with active dehumidification control to continue operating in the occupied mode after everyone leaves the building. This “dry-down” period should last long enough to bring the relative humidity under control in all spaces. Proper use of this technique may allow the units to operate in the unoccupied mode without active dehumidification until the next day.

Exhaust And Makeup Air

Air is removed from the building by local exhaust fans in the space, bathroom and/or kitchen, or with a dedicated central exhaust system. Building pressurization is key to controlling inadvertent infiltration of outdoor air and humidity, as well as assuring proper ventilation airflow. Consequently, a slightly **positive** pressure should be maintained during unoccupied periods as well as during times of occupancy. This means that operation of the exhaust and makeup-air fans must be carefully coordinated. The unit ventilators' OA dampers typically close when the units switch to the unoccupied mode. If the exhaust fans remain on, they'll create a negative pressure inside the building relative to outdoors. Tracer Summit® can help orchestrate the operation of these (and other) system components.

Note: *Economizer operation can increase building pressure enough to limit the introduction of outdoor air. Again, active building pressurization control and system coordination are needed—in this case, to assure proper ventilation.*

System Application Considerations

Reheat Energy Sources

Many different energy sources are available for reheat. They can be categorized as “new energy” and “recovered energy.” **“New-energy” reheat** describes energy expended specifically for the purpose of reheating. Common examples include electric resistance heat and boilers fueled with gas or oil.

Note: Codes in some parts of the country do not permit the use of “new energy” for reheat applications.

“Recovered-energy” reheat refers to the process of salvaging or transferring energy for reheat from another process within the facility—for example, recovering heat from the condenser loop of a water chiller. In this case, the recovered energy is the by-product of a cooling process and is normally rejected or wasted. Condenser water temperatures needed for reheat typically range from 100°F to 110°F in most areas of the country.

Plate-And-Frame Heat Exchanger. One method of recovering energy for reheat is to include a plate-and-frame heat exchanger in the chiller system’s main condenser circuit. See Figure 12. While most systems can attain the

Figure 12
Typical Plate-And-Frame Heat Exchanger Reheat System

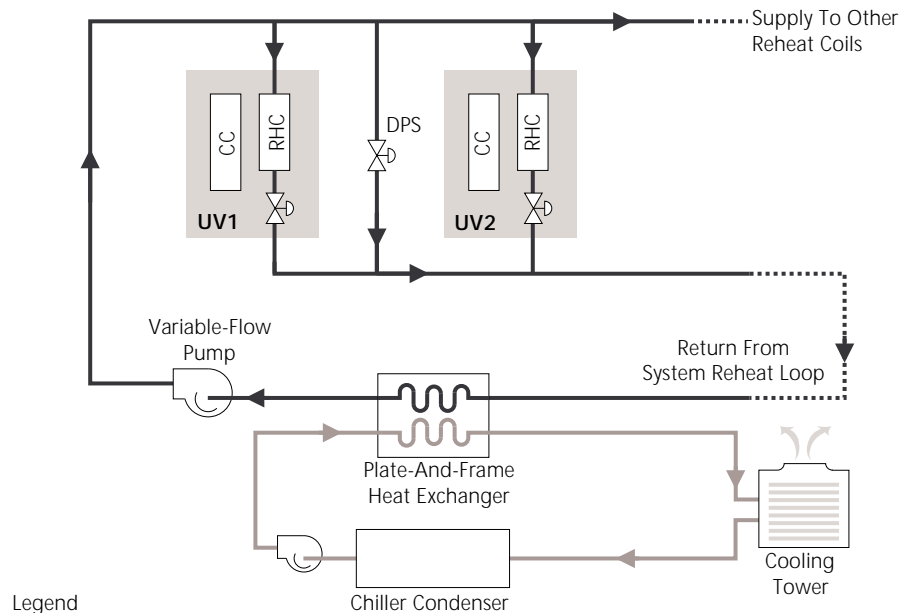

Legend
 CC = Cooling Coil
 DPS = Differential Pressure Switch
 RHC = Reheat Coil
 UV# = Unit Ventilator

System Application Considerations

necessary 100°F to 110°F condenser water temperatures, operating the chiller(s) at this high head condition may penalize the overall efficiency of the chiller system to the point that it offsets the benefit of the recovered heat.

“Heating” Chiller. A dedicated “heating” chiller sized specifically for the reheat load offers another avenue for energy recovery. In this application, several small chillers (for example, Trane Model WXWD’s) are controlled to maintain a constant condenser water temperature. They can be an extremely energy-efficient heat source for satisfying the reheat requirements of dehumidification cycles. More importantly, rejected condenser heat isn’t considered “new energy,” and is permitted for reheat in all states.

Figure 13 shows a typical system schematic for a “heating” chiller application.

Note: Cooling produced by the “heating” chiller is connected to the building’s chilled water loop, but its capacity contribution should **not** be considered when sizing the chiller(s) since it may not be available at all times.

Figure 13
Typical “Heating” Chiller Reheat System

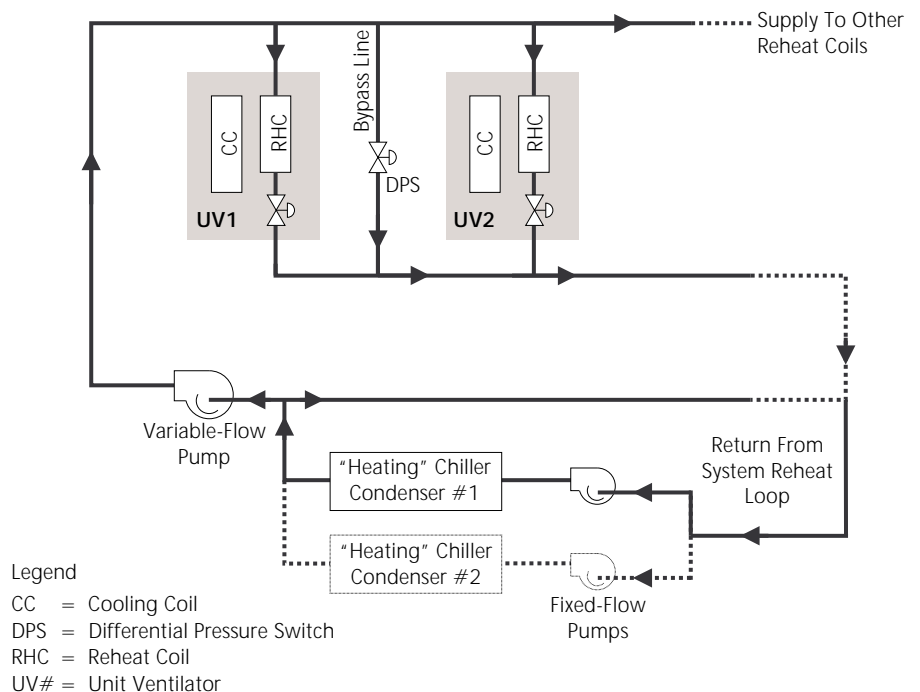

Other Considerations For Good IAQ

So far, we've focused on the importance of managing indoor relative humidity to reduce the potentially harmful effects and material damage caused by the growth of mold and mildew. But many other factors impact indoor air quality. Occupant activities, processes and furnishings indoors play a role, as does the quality of the outdoor air used for ventilation. The facilities manager is ultimately responsible for addressing most of these factors. Certain fundamental features and capabilities of the air handling system can help by significantly reducing the likelihood of the HVAC system and equipment becoming a source of contamination. What *are* these "IAQ basics"?

Condensate pans that drain, and easy accessibility for inspection and cleaning.

All equipment with cooling coils should include fully draining, properly trapped, noncorrosive condensate pans. Standing water in these pans is a well-documented source of mold and fungal growth. Besides contributing odors and propagating spores, this slime can plug drain lines. Costly damage to building materials and furnishings is likely if these lines overflow.

The other key to good indoor air quality is easy access to all parts of the system for inspection, cleaning and maintenance. It's a proven fact that equipment that's most **easily** maintained is most **frequently** maintained.



TRANE™

The Trane Company
North American Commercial Group
3600 Pammel Creek Road
La Crosse, WI 54601-7599

An American-Standard Company

File No. PL-TD-UV-000-EB-11-497

Supersedes New

Since the Trane Company has a policy of continuous product improvement, it reserves the right to change design and specifications without notice.